



RESIDENCIAL



Taj

RESIDENCIAL

O tempo trouxe conquistas.
Trouxe segurança.
Trouxe clareza sobre o que realmente importa.

Agora, a vida pede mais do que um endereço.
Pede um lugar que acompanhe sua evolução.

Um espaço para viver bem.
Para receber com prazer.
Para celebrar o que já foi conquistado
e tudo o que ainda vem pela frente.

Algumas escolhas não são sobre mudar.
São sobre se reconhecer.

E viver exatamente à altura disso.

O ENDEREÇO
QUE ACOMPANHA
SEU RITMO

RUA CASTELO DE GUIMARÃES, 660
CASTELO - BH



PARA QUEM ENTENDE O PRÓPRIO VALOR

3 QUARTOS

74 A 101 m²

APARTAMENTOS GARDEN

169 m²

COBERTURAS DUPLEX

192 m²

LAZER COMPLETO E INCOMPARÁVEL





A PRIMEIRA IMPRESSÃO JÁ DEFINE O PADRÃO

Portaria imponente, com recuo que cria uma praça exclusiva e reforça segurança, distinção e presença no bairro.

A ELEGÂNCIA DE RECEBER BEM

Um hall sofisticado, com materiais nobres e iluminação acolhedora, que reflete a atmosfera de quem escolhe viver melhor.



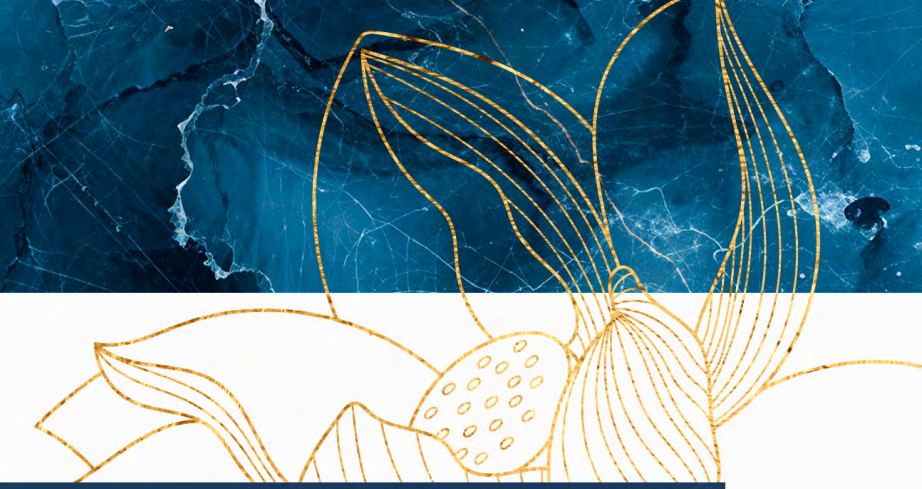

MAIS QUE LAZER, QUALIDADE DE VIDA

Ambientes planejados para relaxar, celebrar, cuidar do corpo e viver com mais qualidade, sem sair de casa.

- 1 - Piscina com deck, prainha e solarium
- 2 - Sauna
- 3 - Gourmet
- 4 - Quadra
- 5 - Salão de festas com amplo terraço
- 6 - Playground
- 7 - Espaço kids
- 8 - Meeting room
- 9 - Espaço beauty
- 10 - Sala de massagem
- 11 - Academia
- 12 - Pet place (térreo)
- 13 - Cozinha do salão de festas
- 14 - Banheiros sociais e PNE
- 15 - Elevadores



O PRIVILÉGIO DE DESACELERAR

Piscina com prainha e sauna integradas em um ambiente que convida a relaxar e viver o conforto em outro nível.





PERSPECTIVA ILUSTRATIVA DA SAUNA

ONDE OS ENCONTROS MUDAM DE PATAMAR

Gourmet amplo, conectado à área externa,
perfeito para celebrar conquistas, fortalecer
laços e viver o prazer de estar junto.



PERSPECTIVA ILUSTRATIVA DO GOURMET



AQUI,
A ENERGIA
ENTRA EM JOGO

Uma quadra pensada para atividades físicas, diversão e momentos que fortalecem corpo, mente e convivência.

DIVERSÃO QUE FAZ PARTE DA ROTINA

Um espaço ao ar livre planejado para que as crianças aproveitem cada momento com segurança e alegria.





ESPAÇO PARA CRESCER COM LIBERDADE

Espaço kids planejado para estimular movimento, criatividade e convivência, sem abrir mão da segurança.

A woman with long, wavy brown hair, wearing a dark blue, sleeveless, form-fitting dress, stands in the foreground. She is looking back over her shoulder towards the camera. The background is a large, modern event hall with several round wooden tables and white chairs. The walls are a warm, light brown color, and there are large windows in the distance. The floor is a light-colored wood or laminate. The overall atmosphere is elegant and sophisticated.

CELEBRAÇÕES À ALTURA DO SEU MOMENTO

Um salão de festas amplo, elegante e acolhedor, preparado para receber com conforto e transformar datas especiais em memórias marcantes.

PERSPECTIVA ILUSTRATIVA DO SALÃO DE FESTAS



PRODUTIVIDADE NO SEU RITMO

Um meeting room reservado, confortável e sofisticado para reuniões, decisões importantes e dias de trabalho com mais foco.

PERSPECTIVA ILUSTRATIVA DO MEETING ROOM

CUIDAR DE SI TAMBÉM É PRIORIDADE

Espaço beauty e sala de massagem pensados para oferecer relaxamento, praticidade e experiências que valorizam sua rotina.





POSITIVE MIND
POSITIVE VIBES
POSITIVE LIVING

DISCIPLINA QUE SUSTENTA CONQUISTAS

Uma academia completa, equipada e moderna para manter o ritmo, cuidar do corpo e evoluir diariamente.



SEU MELHOR AMIGO TAMBÉM MERECE

Um pet place planejado para brincar,
gastar energia e se divertir com seu
companheiro.



MAIS DO QUE MORAR - PERTENCER

Um lar que acompanha seu ritmo,
valoriza seu tempo e oferece o
conforto que sua trajetória merece.

APARTAMENTO TIPO

3 QUARTOS

74 m²

2 VAGAS

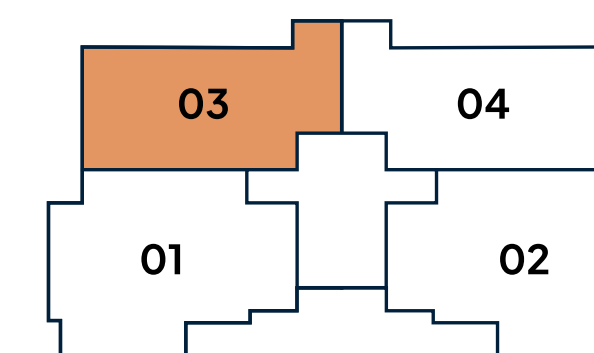

RUA CASTELO DE GUIMARÃES

APARTAMENTO COM TERRAÇO

3 QUARTOS

81 m²

TERRAÇO
2 VAGAS

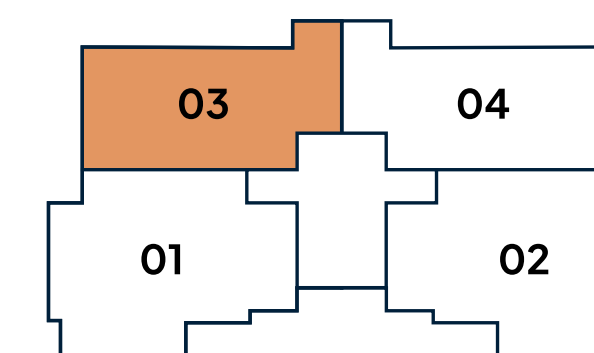

RUA CASTELO DE GUIMARÃES



PERSPECTIVA ILUSTRATIVA DA SALA INTEGRADA COM A COZINHA



A sala se estende ao terraço, ampliando a luminosidade e criando um espaço ideal para relaxar ou receber.



PERSPECTIVA ILUSTRATIVA DA ÁREA DE SERVIÇO

Um espaço contínuo, elegante e funcional, pensado para acompanhar seu ritmo do café da manhã ao jantar com amigos.



APARTAMENTO TIPO

3 QUARTOS

94 m²

VARANDA COBERTA

2 VAGAS

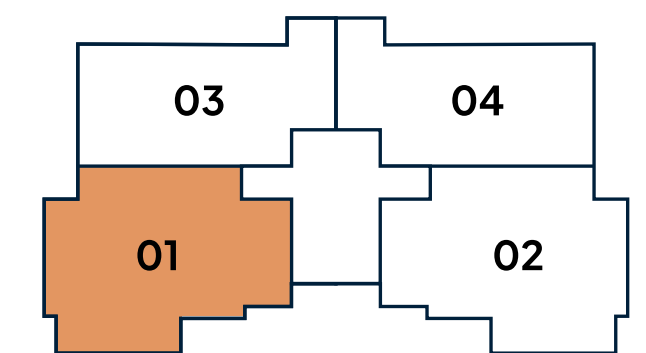

RUA CASTELO DE GUIMARÃES

APARTAMENTO TIPO

3 QUARTOS

96 m²

VARANDA COBERTA

2 VAGAS

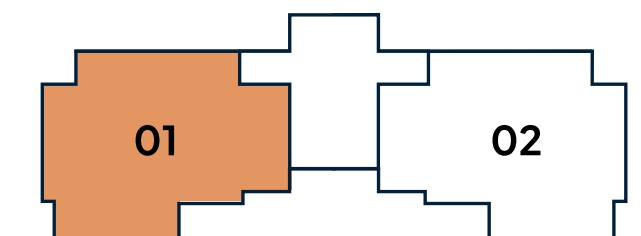

RUA CASTELO DE GUIMARÃES



PERSPECTIVA ILUSTRATIVA DA SALA INTEGRADA COM A COZINHA

A transição fluida entre a sala e a varanda traz mais liberdade para receber e relaxar.





PERSPECTIVA ILUSTRATIVA DA VARANDA DO APTO TIPO DE 94 M²

Amplitude e integração que traduzem
um novo padrão de morar bem.



Mais espaço para descansar,
mais espaço para se organizar,
mais qualidade para viver.



APARTAMENTO COM TERRAÇO

3 QUARTOS

99 m²

TERRAÇO
2 VAGAS

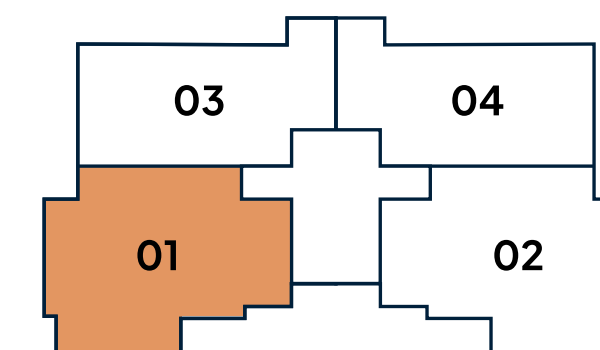

RUA CASTELO DE GUIMARÃES

APARTAMENTO COM TERRAÇO

3 QUARTOS

101 m²

TERRAÇO
2 VAGAS

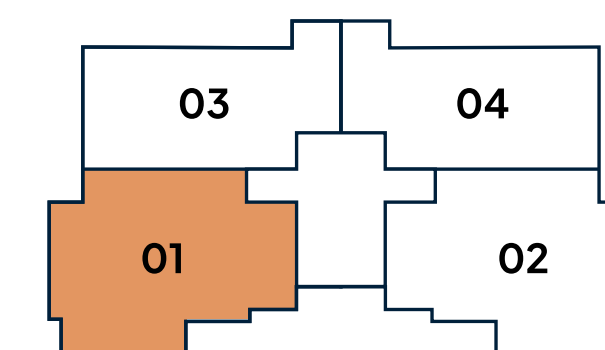

RUA CASTELO DE GUIMARÃES

APARTAMENTO GARDEN

3 QUARTOS

169 m²

AMPLO TERRAÇO
2 OU 3 VAGAS

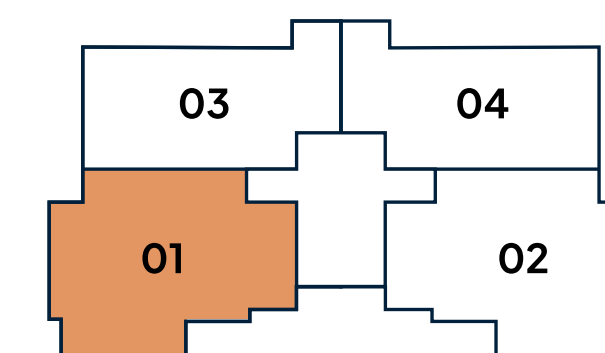

RUA CASTELO DE GUIMARÃES

COBERTURA DUPLEX

3 QUARTOS

192 m²

AMPLO TERRAÇO
3 VAGAS



1º PAVIMENTO

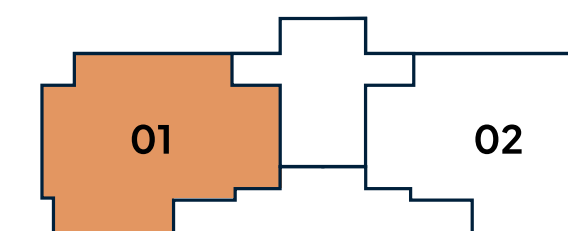

RUA CASTELO DE GUIMARÃES



COBERTURA DUPLEX

2º PAVIMENTO

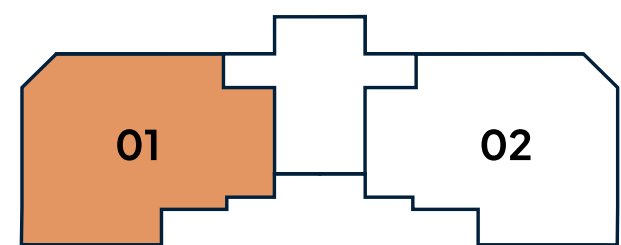

RUA CASTELO DE GUIMARÃES

















FICHA TÉCNICA







EMPREENHIMENTO

 Torre única	 Prédio de esquina recuado e com ampla área verde	 Fachada 100% revestida e afastada com porcelanato	 34 apartamentos tipo com 2 vagas
 12 apartamentos com terraço e 2 vagas	 2 apartamentos garden com 3 vagas	 2 coberturas duplex com 3 vagas	 2 elevadores
 Portaria com eclusa	 Preparação para portaria virtual	 Área para delivery na eclusa	 Infraestrutura para sistema de segurança e CFTV

ÁREAS COMUNS E LAZER

 1.100 m ² de lazer	 Acesso por biometria nas áreas comuns	 Hall social	 Piscina com deck, prainha e solarium	 Sauna	 Gourmet
 Quadra	 Salão de festas com amplo terraço	 Playground	 Espaço kids	 Meeting room	 Espaço beauty
 Sala de massagem	 Academia	 Pet place			

APARTAMENTO

 Apartamento com piso em porcelanato, sendo nos quartos no estilo amadeirado	 Banheiros 100% revestidos	 Distribuição individual de água no sistema de shafts	 Gás individualizado	 Esquadrias de 3 folhas	 Laje técnica e estrutura predial com previsão para instalação de ar-condicionado*	 Estrutura convencional que permite alterações internas do apartamento pós-entrega
--	--	---	--	---	--	--

*Não inclui equipamentos.



A EXCELÊNCIA EM NOSSO DNA

A Emag pertence ao sólido Grupo Agmar cuja história de 50 anos se destaca no mercado imobiliário de Belo Horizonte. Mais que prédios, nossa missão é construir lares que proporcionem conforto, segurança e felicidade aos nossos clientes. Criamos projetos modernos e funcionais, com ambientes cuidadosamente planejados, e com uma ótima relação custo/benefício para atender às necessidades e ao estilo de vida de cada família.

Conte conosco e com o nosso legado para tornar realidade o seu sonho de morar bem.

PARCEIROS:





VENDAS:

 **3343-8000**

 **97170-8772**

ESTANDE DE VENDAS:

RUA CASTELO DE GUIMARÃES, 660 – CASTELO

emagconstrutora.com.br